

GROUP E

59	2, 5, 15, 16, 28, 35, 42, 58, 86
60	4, 5, 6
61	7, 42, 43, 44, 45, 46, 47, 48, 49, 50, 51, 52, 53, 54, 57, 58
62	42, 43, 44, 45, 46, 47, 48, 49, 50, 51, 52, 53, 54, 56, 57, 58
63	23, 24, 25

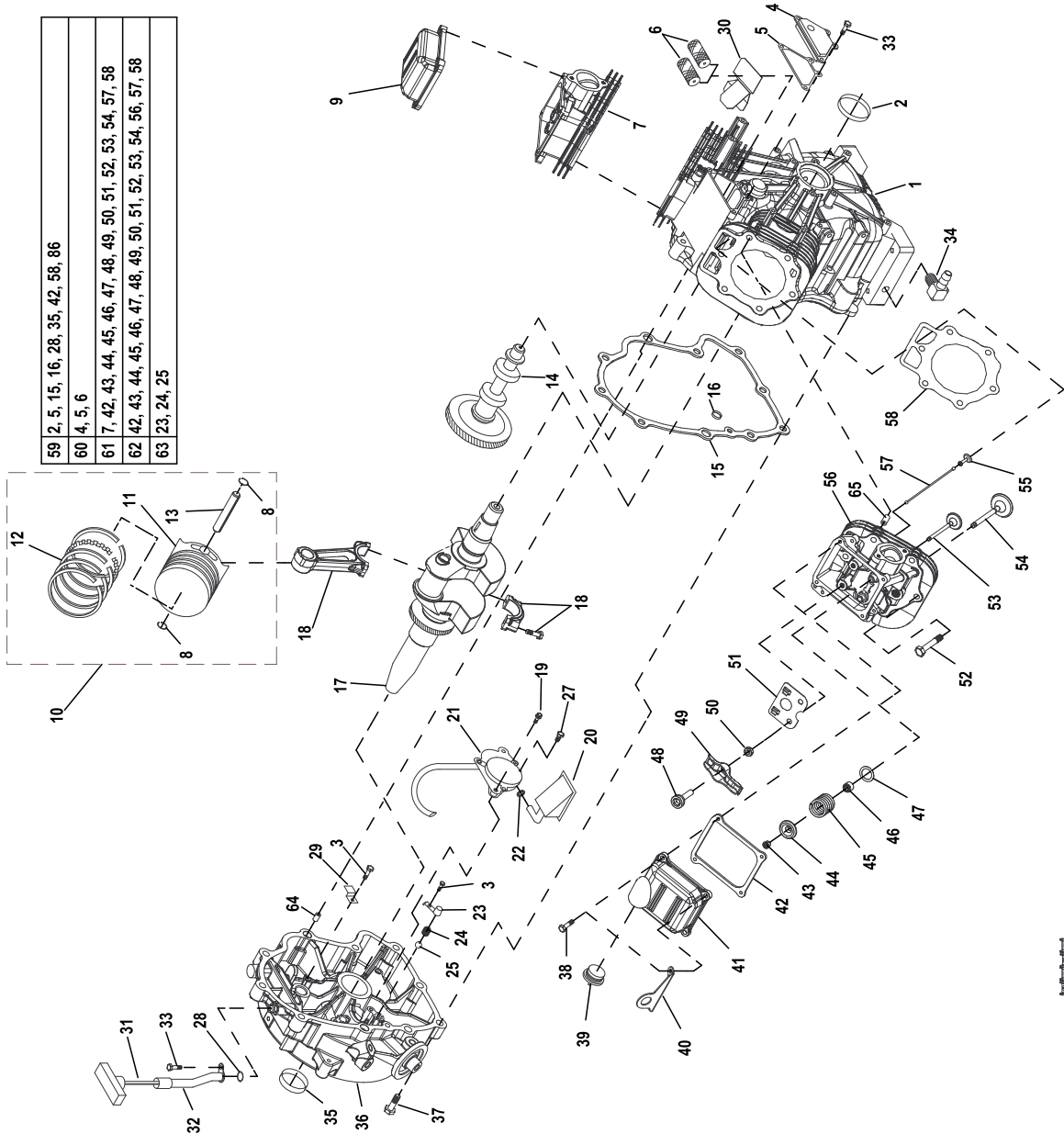

DECAL DATA ENG-SIZE
020527

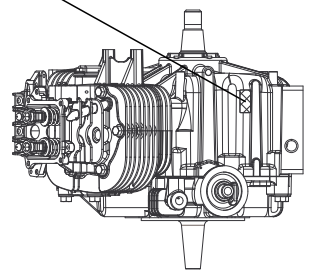

NOT SHOWN ON SERVICE EV	
P/N:	DESC:
020527 *	DECAL DATA ENG-SIZE
010599	OIL D30D RUN-IN-OIL
0A2767 *	PIPE SEALANT LCITE-565

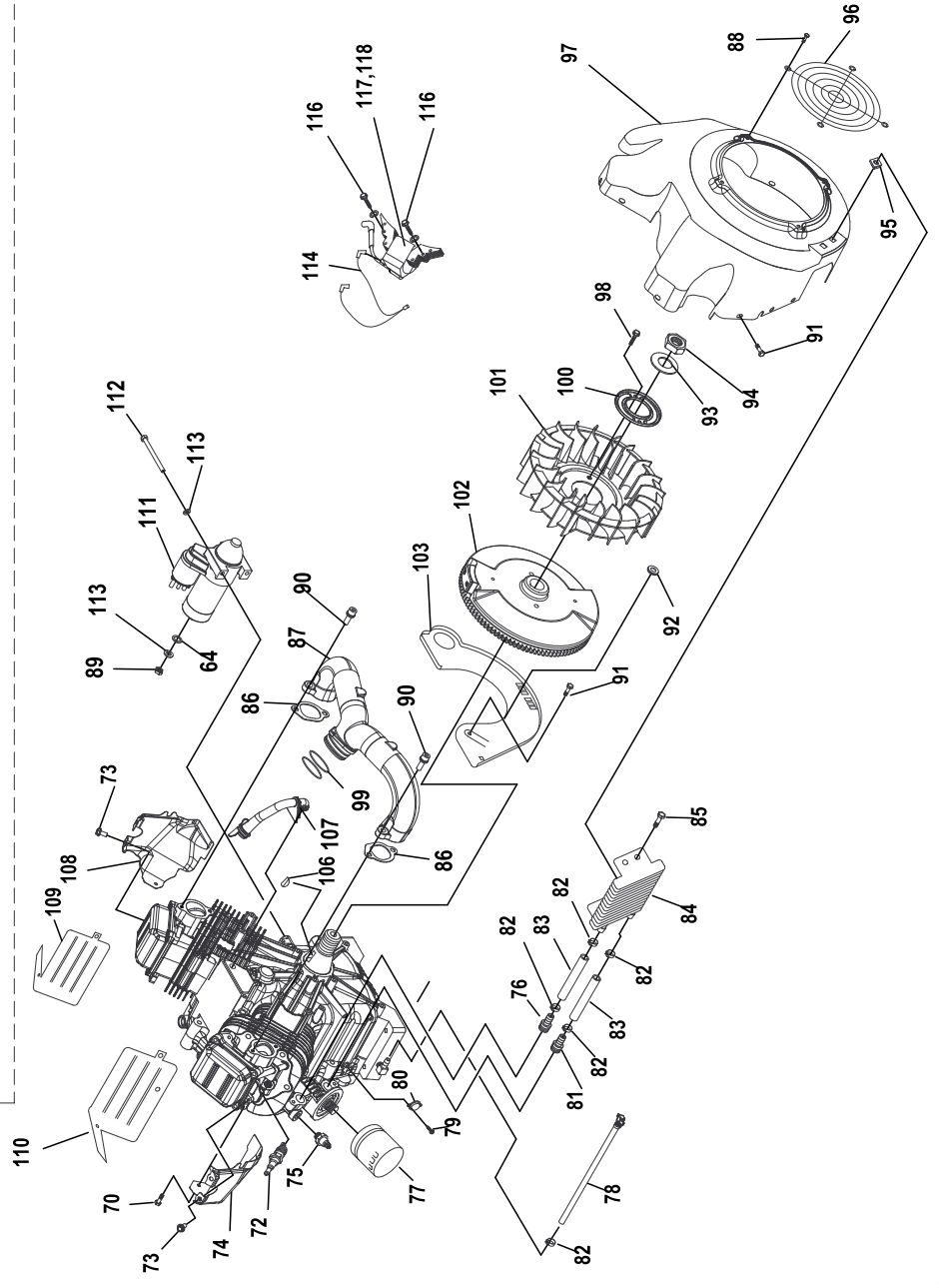
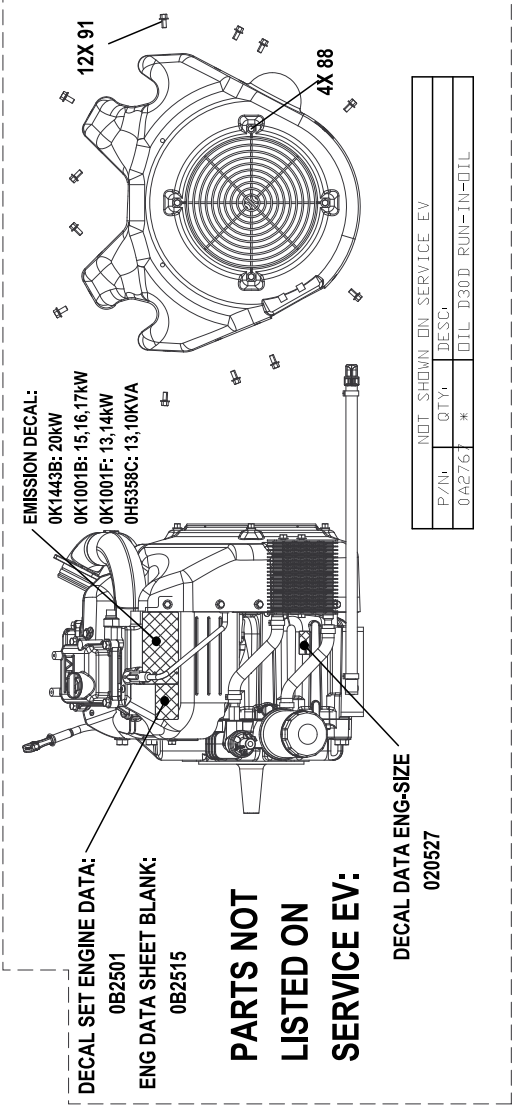

EXPLODED VIEW: EV ENGINE GTH990-999 HSB 2013

DRAWING #: 0J9882

GROUP E

ITEM	PART#	QTY.	DESCRIPTION
		PAGE 1	
1	0G8548	1	ASSY CRANKCASE WITH SLEEVE
2	0K1534	1	SEAL CRANKSHAFT FLYWHEEL RED
3	0G0919	3	SCREW HHFCS M6-1.0 X 12 G8.8
4	0G9100	1	ASSEMBLY, BREATHER DUAL VALVE
5	0C3005	1	GASKET, BREATHER COVER
6	0E3372C	2	SEPARATOR, OIL BREATHER
7	0H1760A	1	ASSY HEAD CYL #1
8	071983	4	RETAINER, PISTON PIN 20
9	0C2981C	1	ROCKER, COVER NO OIL FILL
10	0K1633	2	ASSY PISTON FLAT TOP
11	0K0988	2	PISTON, FLAT TOP DIA 90 COATED
12	0G2565	2	RING SET, PISTON DIA 90
13	0G7940	2	PIN, PISTON
14	0D4041	1	ASSY, CAMSHAFT & GEAR (13,14,16,17KW)
	0G7974	1	ASSY, CAMSHAFT & GEAR (20KW)
15	0C2977	1	GASKET, CRANK CASE
16	0C5943	1	SEAL, OIL PASSAGE
17	0E4357E	1	ASSY, CRANK & GEAR (13,14,16,17KW)
	0G5001E	1	ASSY,C'SHAFT 0.D. 41 (20KW)
	0K6529E	1	ASSY,C'SHAFT 999 (22KW)
18	0J8969	2	ASSY CONROD MACH GT990 (13,14,16,17KW)
	0J8968	2	ASSY CONROD MACH GT999 (20KW)
	0J8968A	2	ASSY CONROD MACH GT999 (22KW)
19	0G6431	2	SCREW SHC SEMS M6-1.0 X 50 G8.8
20	0E6098	1	SCREEN, OIL PICKUP
21	0D4123B	1	ASSEMBLY, OIL PUMP W/O O-RING
22	0E8152	1	O-RING .49 ID X .07 THICK
23	0C3011	2	COVER, OIL RELIEF
24	0C3009	2	SPRING, OIL RELIEF
25	0C3010	2	BALL, 1/2D OIL RELIEF
27	0F5458	1	SCREW, PLASTITE HI-LOW #10
28	0C3027	1	O-RING, 3/8" X 1/2"
29	0C5998	1	CLAMP, OIL TUBE
30	0G8558	1	DIVERTER,BREATHER GTH
31	0H6859L	1	ASSEMBLY, DIPSTICK WITH HANDLE ORG
32	0K1050	1	TUBE, DIPSTICK
33	0D6147	5	SCREW HHFC M6-1.0 X 10mm
34	043790A	1	BARBED ELBOW 90 3/8NPT X 3/8 VS
35	0K2035	1	SEAL CRANKSHAFT PTO RED
36	0F8054	1	GEARCOVER / ADAPTOR GTH-990
37	0C3006	10	SCREW, HHFC M10-1.5 X 55
38	080318	8	SCREW HHFC M6-1.0 X 25
39	093064A	1	ASSEMBLY, OIL FILL CAP ORG
40	0K4867	2	LIFT HOOK GT990/760
41	0D2723B	1	ROCKER, COVER WITH OIL FILL
42	0C2979	2	GASKET, VALVE COVER
43	086515	8	KEEPER, VALVE SPRING
44	0D2274	4	RETAINER, VALVE SPRING
45	0D3867	4	SPRING, VALVE
46	078672	2	SEAL, VALVE STEM D7
47	0C5371	4	WASHER, VALVE SPRING
48	072694	4	STUD, ROCKER ARM PIVOT
49	0D5313	4	ROCKER ARM
50	0D3998	4	NUT HEX M8-1.0 G8 YEL CHR
51	0J9679	2	PLATE, PUSH ROD GUIDE
52	0C2976	12	SCREW HHFC M8-1.25 X 65
53	086516	2	VALVE, EXHAUST
54	0C2229	2	VALVE, INTAKE
55	083897	4	TAPPET, SOLID
56	0H1760B	1	ASSY HEAD CYL #2
57	0D9853D	4	PUSHROD, 147
58	0C2978	2	GASKET, HEAD
	0K6409	1	GASKET, HEAD (22KW)
59	0D4010	1	KIT GASKET

EXPLODED VIEW: EV ENGINE GTH990-999 HSB 2013

DRAWING #: 0J9882

GROUP E

ITEM	PART#	QTY.	DESCRIPTION
60	0D4012	1	KIT BREATHER ASSEMBLY
61	0D8675A	1	KIT HEAD ASSEMBLY CYLINDER 1
62	0D8675B	1	KIT HEAD ASSEMBLY CYLINDER 2
63	0D4015	1	KIT OIL RELIEF
64	078699C	2	SLEEVE DOWEL PIN 14 DIA.
65	078699B	4	SLEEVE DOWEL PIN 12 DIA.
66	0C4166	1	SLEEVE PTO BEARING [NOT SHOWN]
PAGE 2			
64	022145	1	WASHER FLAT M8 – 5/16
70	0G0919	2	SCREW M6-1.0 X 12
72	0E7585A	2	SPARKPLUG, RCY14 .040" GAP (13,14,16,17Kw)
	0G0767A	2	SPARKPLUG, RC12 .040" GAP (20Kw)
73	0E6043	2	SCREW TAPTITE M5 – 0.8 X 8
74	0G7606	1	WRAPPER, LOWER CYLINDER 2 ZINC
75	0G6820	1	SWITCH, OIL PRESS
76	0H6244	1	EXTENDED BARBED STR ¼ NPT X 3/8
77	070185E	1	OIL FILTER, 90mm
78	0H8131	1	ASSY, OIL DRAIN HOSE ORG
79	0A7095	2	SCREW PPHM #4-40 X 5/16 SEMS
80	094090	1	SWITCH, THERMAL 293F
81	035461	1	BARBED STRAIGHT 1/4NPT X 3/8
82	0G3662B	5	CLAMP, HOSE OETIKER STEPLESS 18.5mm
83	0F0452C	2	HOSE 3/8" 300PSI 6" LG OIL
84	0E9506	1	COOLER, OIL
85	0C9764	4	SCREW PLASTITE 1/4-15 X 3/4
86	0C3043	2	GASKET, MANIFOLD / PORT
87	0J9765	1	MANIFOLD INT GTH999 2X
88	045756	4	SCREW, HHTT M6-1 x 10 LONG
89	082025	1	NUT, HEX LOCK M5-0.8 ZINC
90	0G3730A	4	SCREW SHC M8 – 1.25 X 30 SEMS
91	090388	16	SCREW TAPTITE M6-1X12 CLEAR ZINC
92	0K1307	1	GROMMET 3/16 X 1/16
93	0C3033	1	WASHER, 25MM I.D.
94	0C3034	1	NUT, HEX M24
95	0C9763	4	NUT, GROMMET 1/4 PLUG
96	0D1131	1	GUARD, FAN
97	0F1169K	1	HOUSING, BLOWER NG COOLER
98	0H4957	2	SCREW HHFCS M8 – 1.25 X 10 G8.8
99	0K0710	2	O-RING 1-3/4 X 1/16
100	0C3032	1	PLATE, FAN
101	0C3031	1	FAN, NYLON
102	0C3725B	1	ASSY, FLYWHEEL (13,14,16,17Kw)
	0C3725D	1	ASSY, FLYWHEEL (20Kw)
	0C3725F	1	ASSY, FLYWHEEL (22Kw/VSCF)
103	0G4928C	1	PLATE, BACKING WITH CUT OUT
106	082774	1	KEY, WOODRUFF 4 X 19D
107	0K3134	1	HOSE BREATHER
108	0G7604	1	WRAPPER, LOWER CYLINDER 1 ZINC
109	0G7603	1	WRAPPER, UPPER CYLINDER 1 ZINC
110	0G7605	1	WRAPPER, UPPER CYLINDER 2 ZINC
111	0E9323	1	STARTER MOTOR HEAR REDUCED 1KW
112	061906	2	SCREW HHC M8 – 1.25 X 85 G8.8
113	022129	3	WASHER LOCK M8 – 5/16
114	0K1280	1	ASSEMBLY, GROUND WIRE
116	0G3110	4	SCREW TAPTITE M6 – 1.0 X 20 ZINC
117	0G3224TA	1	ASSY, IGN COIL W/DIODE, CYLINDER 1
118	0G3224TB	1	ASSY, IGN COIL W/DIODE, CYLINDER 2
119	082025	1	NUT HEX LOCK M5X 0.8

GROUP D

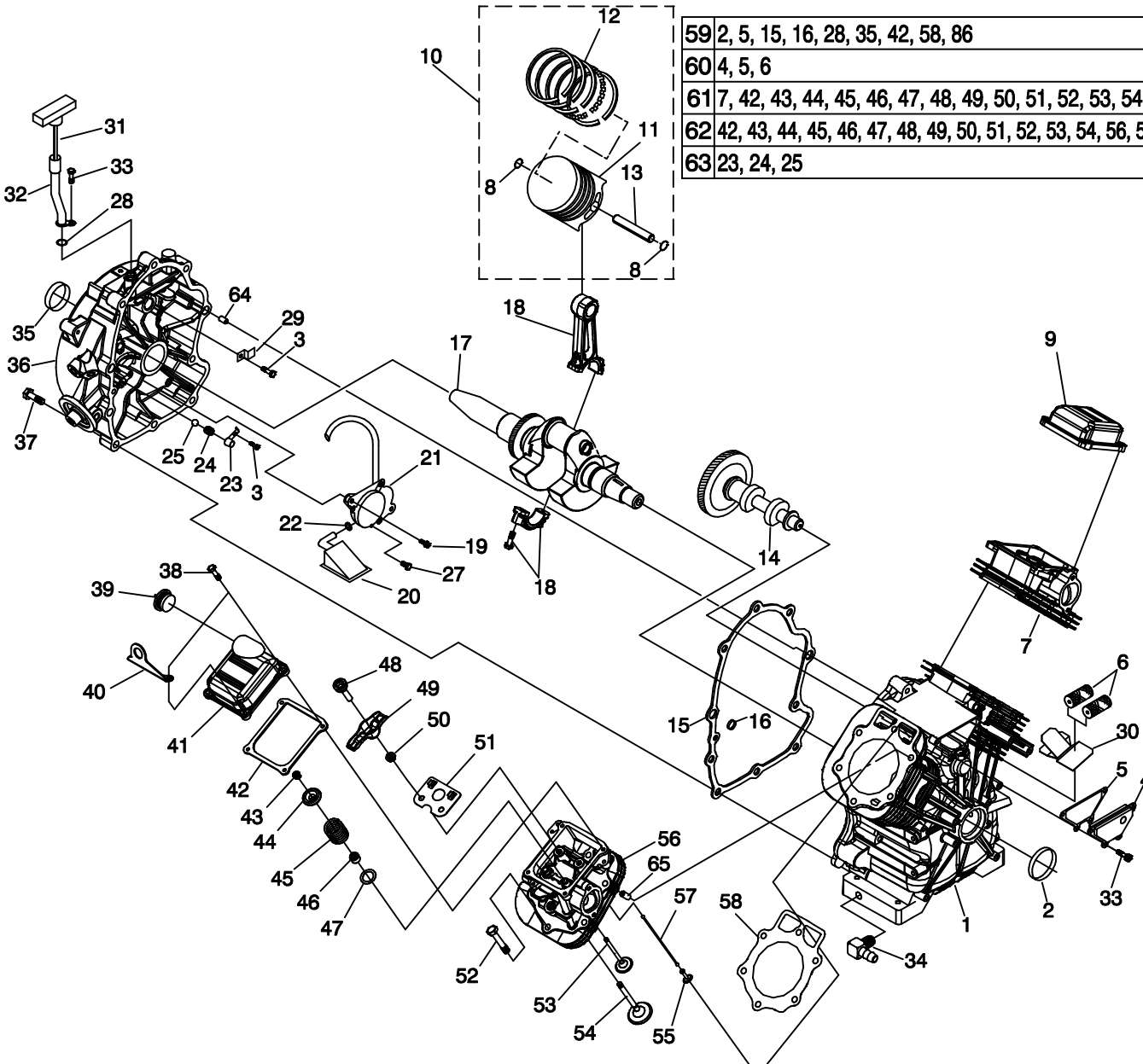

59	2, 5, 15, 16, 28, 35, 42, 58, 86
60	4, 5, 6
61	7, 42, 43, 44, 45, 46, 47, 48, 49, 50, 51, 52, 53, 54, 57, 58
62	42, 43, 44, 45, 46, 47, 48, 49, 50, 51, 52, 53, 54, 56, 57, 58
63	23, 24, 25

EXPLODED VIEW: ENGINE GH990/999 HSB 2013

DRAWING #: 0J9882

APPLICABLE TO: HSB 2013

GROUP D

ITEM	PART #	QTY.	DESCRIPTION	ITEM	PART #	QTY.	DESCRIPTION
1	0G8548	1	ASSY CRANK CASE WITH SLEEVE	51	0J9679	2	PLATE, PUSH ROD GUIDE
2	0K1534	1	SEAL CRANKSHAFT FLYWHEEL RED	52	0C2976	12	SCREW HHFC M8-1.25 X 65
3	0G0919	3	SCREW HHFC M6-1.0 X 12 G8.8	53	086516	2	VALVE, EXHAUST
4	0G9100	1	ASSEMBLY, BREATHER DUAL VALVE	54	0C2229	2	VALVE, INTAKE
5	0C3005	1	GASKET, BREATHER COVER	55	083897	4	TAPPET, SOLID
6	0E3372C	2	SEPARATOR, OIL BREATHER	56	0H1760B	1	ASSY HEAD CYL #2
7	0H1760A	1	ASSY HEAD CYL #1	57	0D9853D	4	PUSH ROD, 147
8	071983	4	RETAINER, PISTON PIN 20	58	0C2978	2	GASKET, HEAD
9	0C2981C	1	ROCKER, COVER NO OIL FILL		0K6409	2	GASKET, HEAD (22KW)
10	0K1633	2	ASSY PISTON FLAT TOP	59	0D4010	1	KIT GASKET
11	0K0988	2	PISTON, FLAT TOP DIA 90 COATED	60	0D4012	1	KIT BREATHER ASSEMBLY
12	0G2565	2	RING SET, PISTON DIA 90	61	0D8675A	1	KIT HEAD ASSEMBLY CYLINDER 1
13	0G7940	2	PIN, PISTON	62	0D8675B	1	KIT HEAD ASSEMBLY CYLINDER 2
14	0D4041	1	ASSY, CAMSHAFT & GEAR (13,14,16,17KW)	63	0D4015	1	KIT OIL RELIEF
	0G7974	1	ASSY, CAMSHAFT & GEAR (20KW)	64	078699C	2	SLEEVE DOWEL PIN 14 DIA.
15	0C2977	1	GASKET, CRANK CASE	65	078699B	4	SLEEVE DOWEL PIN 12 DIA.
16	0C5943	1	SEAL, OIL PASSAGE	66	0C4166	1	SLEEVE PTO BEARING [NOT SHOWN]
17	0E4357E	1	ASSY, CRANK & GEAR (13,14,16,17KW)				
	0G5001E	1	ASSY, C'SHAFT 0.D. 41 (20 KW)				
	0K6529E	1	ASSY, C'SHAFT 999 (22 KW)				
18	0J8969	2	ASSY CONROD MACH GT990 (13,14,16,17KW)				
	0J8968	2	ASSY CONROD MACH GT999 (20KW)				
19	0G6431	2	SCREWS HC SEMS M6-1.0 X 50 G8.8				
20	0E6098	1	SCREEN, OIL PICK UP				
21	0D4123B	1	ASSEMBLY, OIL PUMP W/O O-RING				
22	0E8152	1	O-RING .49 ID X .07 THICK				
23	0C3011	2	COVER, OIL RELIEF				
24	0C3009	2	SPRING, OIL RELIEF				
25	0C3010	2	BALL, 1/2D OIL RELIEF				
27	0F5458	1	SCREW, PLASTITE HI-LOW #10				
28	0C3027	1	O-RING, 3/8" X 1/2"				
29	0C5998	1	CLAMP, OIL TUBE				
30	0G8558	1	DIVERTER, BREATHER GTH				
31	0H6859L	1	ASSEMBLY, DIPSTICK WITH HANDLE ORG				
32	0K1050	1	TUBE, DIPSTICK				
33	0D6147	5	SCREW HHFC M6-1.0 X 10mm				
34	043790A	1	BARBED ELBOW 90 3/8 NPT X 3/8 VS				
35	0K2035	1	SEAL CRANKSHAFT PTO RED				
36	0F8054	1	GEARCOVER / ADAPTOR GTH-990				
37	0C3006	10	SCREW, HHFC M10-1.5 X 55				
38	080318	8	SCREW HHFC M6-1.0 X 25				
39	093064A	1	ASSEMBLY, OIL FILL CAP ORG				
40	0K4867	2	LIFT HOOK GT990/760				
41	0D2723B	1	ROCKER, COVER WITH OIL FILL				
42	0C2979	2	GASKET, VALVE COVER				
43	086515	8	KEEPER, VALVE SPRING				
44	0D2274	4	RETAINER, VALVE SPRING				
45	0D3867	4	SPRING, VALVE				
46	078672	2	SEAL, VALVE STEM D7				
47	0C5371	4	WASHER, VALVE SPRING				
48	072694	4	STUD, ROCKER ARM PIVOT				
49	0D5313	4	ROCKER ARM				
50	0D3998	4	NUT HEX M8-1.0 G8 YEL CHR				

GROUP D

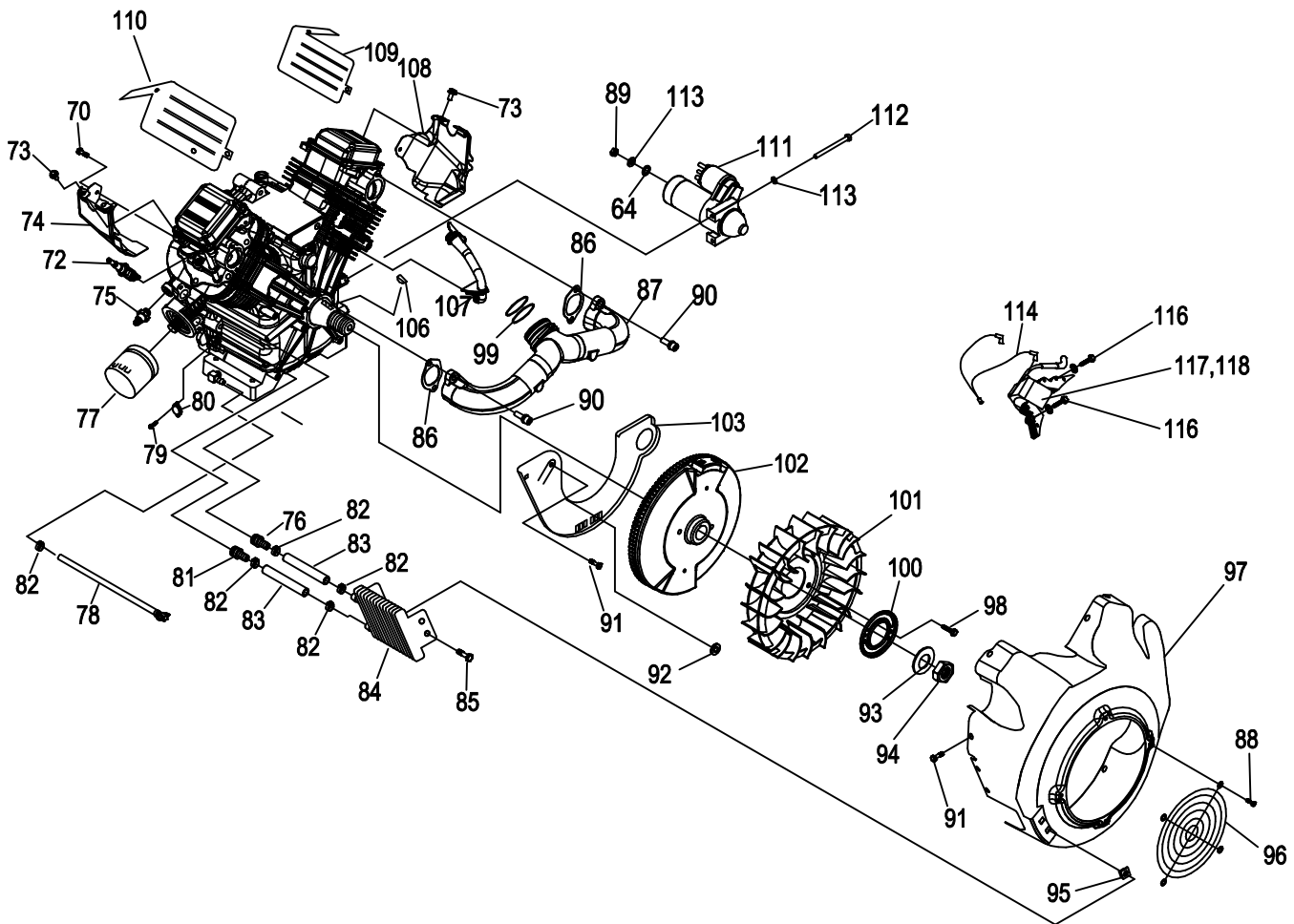

EXPLODED VIEW: ENGINE GH990/999 HSB 2013
 DRAWING #: 0J9882

GROUP D

APPLICABLE TO: HSB 2013

ITEM	PART #	QTY.	DESCRIPTION
64	022145	1	WASHER FLAT M8 - 5/16
70	0G0919	2	SCREW M6-1.0 X 12
72	0E7585A	2	SPARKPLUG, RCY14 .040" GAP (13,14,16,17Kw)
	0G0767A	2	SPARKPLUG, RC12 .040" GAP (20Kw)
73	0E6043	2	SCREW TAPTITE M5 - 0.8 X 8
74	0G7606	1	WRAPPER, LOWER CYLINDER 2 ZINC
75	0G6820	1	SWITCH, OIL PRESS
76	0H6244	1	EXTENDED BARBED STR 1/4 NPT X 3/8
77	070185E	1	OIL FILTER, 90mm
78	0H8131	1	ASSY, OIL DRAIN HOSE ORG
79	0A7095	2	SCREW PPHM #4-40 X 5/16 SEMS
80	094090	1	SWITCH, THERMAL 293F
81	035461	1	BARBED STRAIGHT 1/4NPT X 3/8
82	0G3662B	5	CLAMP, HOSE OETIKER STEPLESS 18.5mm
83	0F0452C	2	HOSE 3/8" 300PSI 6" LG OIL
84	0E9506	1	COOLER, OIL
85	0C9764	4	SCREW PLASTITE 1/4-15 X 3/4
86	0C3043	2	GASKET, MANIFOLD / PORT
87	0J9765	1	MANIFOLD INT GTH999 2X
88	045756	4	SCREW, HHTT M6-1 x 10 LONG
89	082025	1	NUT, HEX LOCK M5-0.8 ZINC
90	0G3730A	4	SCREW SHC M8 - 1.25 X 30 SEMS
91	090388	16	SCREW TAPTITE M6-1X12 CLEAR ZINC
92	0K1307	1	GROMMET 3/16 X 1/16
93	0C3033	1	WASHER, 25MM I.D.
94	0C3034	1	NUT, HEX M24
95	0C9763	4	NUT, GROMMET 1/4 PLUG
96	0D1131	1	GUARD, FAN
97	0F1169K	1	HOUSING, BLOWER NG COOLER
98	0H4957	2	SCREW HHFCS M8 - 1.25 X 10 G8.8
99	0K0710	2	O-RING 1-3/4 X 1/16
100	0C3032	1	PLATE, FAN
101	0C3031	1	FAN, NYLON
102	0C3725B	1	ASSY, FLYWHEEL (13,14,16,17Kw)
	0C3725D	1	ASSY, FLYWHEEL (20Kw)
	0C3725F	1	ASSY, FLYWHEEL (22Kw/VSCF)
103	0G4928C	1	PLATE, BACKING WITH CUT OUT
106	082774	1	KEY, WOODRUFF 4 X 19D
107	0K3134	1	HOSE BREATHER
108	0G7604	1	WRAPPER, LOWER CYLINDER 1 ZINC
109	0G7603	1	WRAPPER, UPPER CYLINDER 1 ZINC
110	0G7605	1	WRAPPER, UPPER CYLINDER 2 ZINC
111	0E9323	1	STARTER MOTOR HEAR REDUCED 1KW
112	061906	2	SCREW HHC M8 - 1.25 X 85 G8.8
113	022129	3	WASHER LOCK M8 - 5/16
114	0K1280	1	ASSEMBLY, GROUND WIRE
116	0G3110	4	SCREW TAPTITE M6 - 1.0 X 20 ZINC
117	0G3224TA	1	ASSY, IGN COIL W/DIODE, CYLINDER 1
118	0G3224TB	1	ASSY, IGN COIL W/DIODE, CYLINDER 2
119	082025	1	NUT HEX LOCK M5X 0.8

ITEM	PART #	QTY.	DESCRIPTION
------	--------	------	-------------